

Jet Metals Gutter HD System

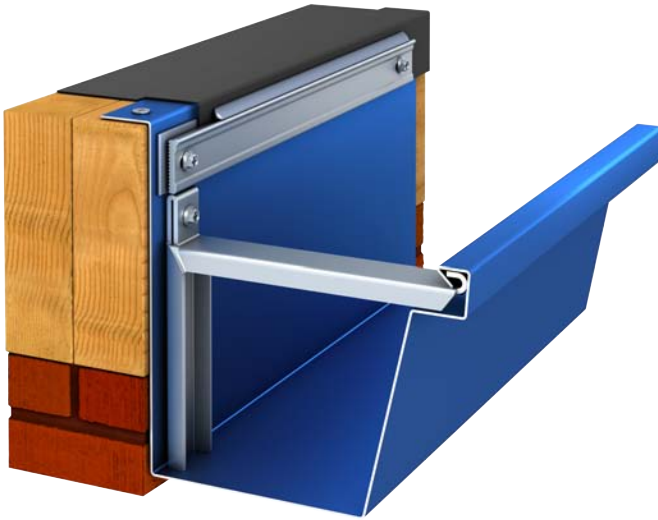

Overview

The Jet Metals Gutter HD System is a Heavy Duty Gutter used with single-ply commercial roof systems. Our 7" Box Gutter is available in both pre-painted Kynar500® .040 formed aluminum and 24 gauge galvalume steel. Available in standard lengths of 10' and includes all gutter brackets (spaced 24" on center) and fasteners.

Features and Benefits

- ▤ Strongest Gutter System on the market today
- ▤ High Performance Gutter Bracket Systems
- ▤ ANSI-SPRI ES-1 Certified
- ▤ Gutter Bracket is perfect for Salt environments with 0.040 aluminum.
- ▤ Gold Standard Paint 35-Year Warranty
- ▤ Corporate and Custom Colors are available



Installation

For complete installation instructions, please refer to Jet Metals Architectural specifications and details.

REVIEW CURRENT JET METALS ARCHITECTURAL SPECIFICATION AND DETAILS FOR SPECIFIC INSTALLATION REQUIREMENTS.

Quality Assurance

Jet Metals Gutter HD system is tested per ANSI/SPRI Test Method GD-1 / GD-2 and GD-3 Structural Design Standard for Low Slope Roofs. . The Gutter HD system shall be certified by Jet Metals to design pressures as indicated in current edition of SPRI's Wind Resistance Standard for Edge Systems used with Low Slope Roofing System. This products meets International Building Code minimum requirement.

Technical Services

Engineering and shop drawings, as well as long-form specifications and CAD details, are available from Jet Metals. Product samples, detail sheets, color chips and color charts are also available for submittal packages. For personal assistance with questions or for full submittals, contact Jet Metals or your local independent sales representative.

Specifications

Material	Size	Sustained Pressures
24 gauge	7"	-200 / -50 - / - 430 psf (*)
0.040 AL	7"	-230 / -60 - / - 430 psf (*)

* Design Engineer must apply the Factor of Safety

**ADDITIONAL GAUGES - .050 and .063 aluminum and 22 gauge Galvalume are available upon request

677 Celriver Road, Rock Hill, SC 29730
 Phone: 866.696.1475
 Fax: 803.325.8705
 web: jetmetals.com
 email: eburns@jetmetals.com



Installation Guide for Gutter HD

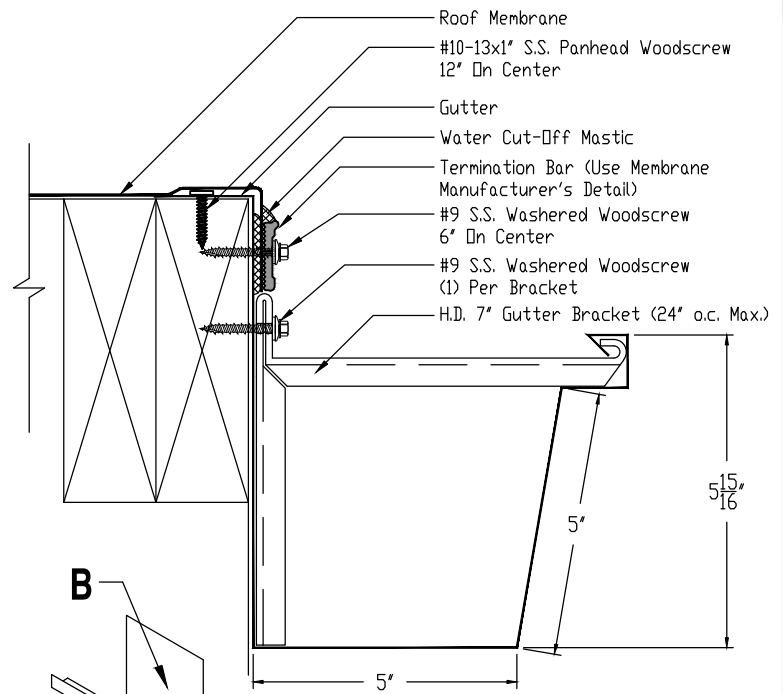

NOTES:

- #1 - Isolate all metal parts from ACQ treated wood or other galvanically incompatible material with appropriate membrane material.
- #2 - Appliance attachments, such as lightning rods, signs, or antennae that penetrate the water seal, induce a galvanic reaction, or otherwise compromise the effectiveness of the roof edge system, shall be eliminated or isolated to prevent problems per section 8.0 if ANSI/SPRI ES-1. Appliances should also be isolated from, or not attached to, the roof edge system. Consult the lightning protection system manufacturer for specific attachment instructions.

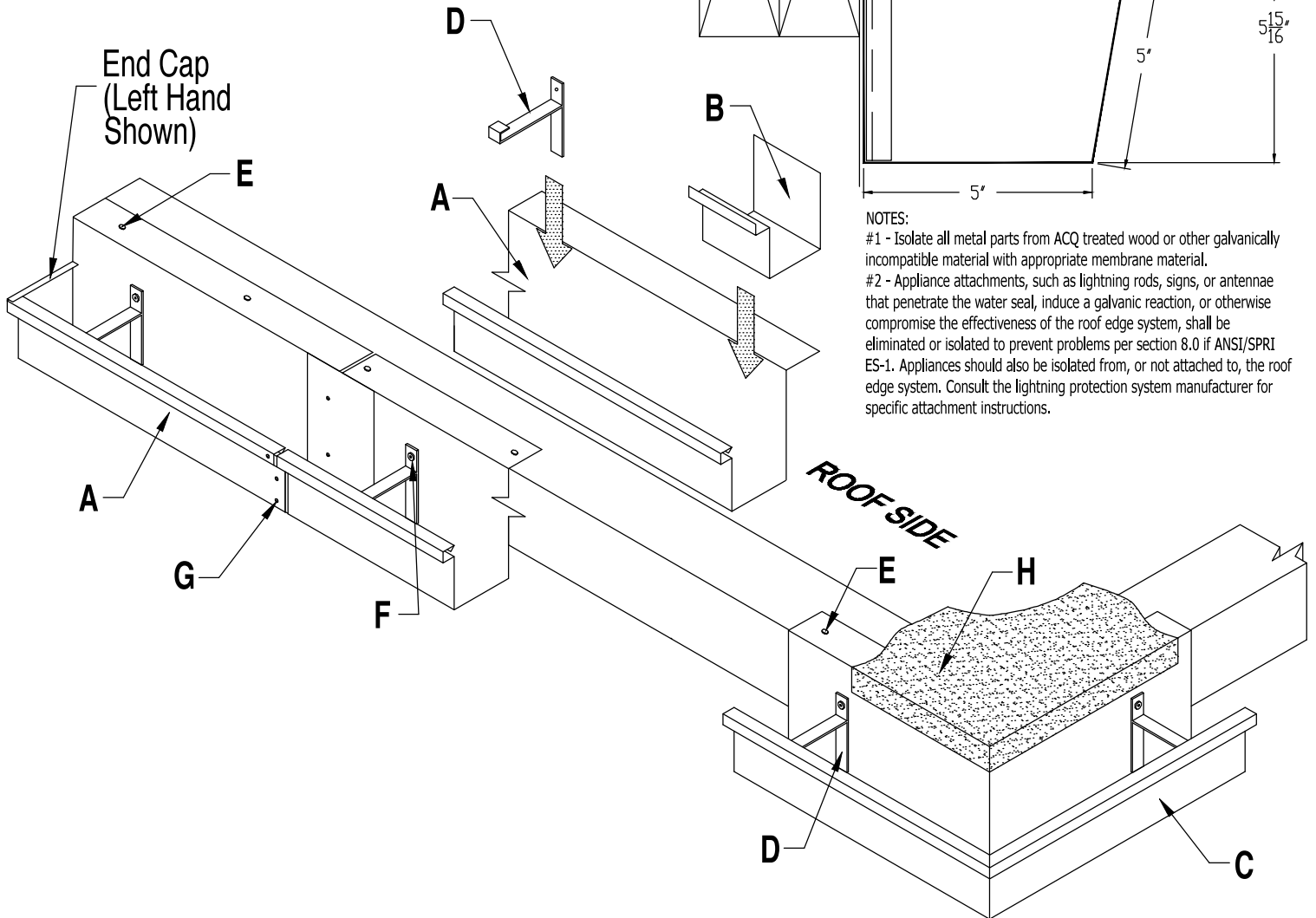

- A. Gutter HD Flashing**
 10'-0" Std. Lengths (20'-0" Max.)
- B. Gutter Splice Plate**
 10'-0" Lengths
- C. Gutter Miter**
 (Outside Corner Shown)
- D. Gutter HD Bracket**
 (24" o.c. Max.)

- E. #10-13x1" S.S. Panhead Woodscrew**
 at 12" o.c. (Included and Required)
- F. #9-13x1-1/2" S.S. Washered Screw**
 1 per Bracket (Included and Required)
- G. Pop Rivet**
- H. Approved Roofing Membrane**
 (By Installer)



DOWNSPOUT OUTLET TUBE

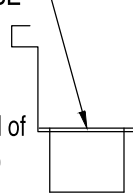

STEP 1 : Installing Downspout Outlet Tubes

Determine outlet locations and field cut hole in the gutter bottom. Insert Outlet Tube in hole, apply a continuous bead of urethane Tube Sealant to the flange and fasten with two (2) Pop Rivets in each flange from outside the gutter bottom.

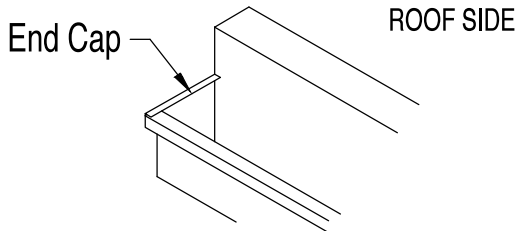

STEP 2 : Installing Gutter End Caps

Locate the End Caps for the appropriate gutter end. Place the End Cap into position and secure to gutter with Pop Rivets. Apply a continuous bead of urethane Tube Sealant around the inside flange of the End Cap.

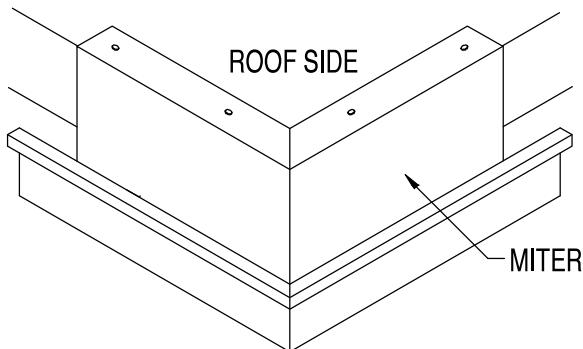

STEP 3 : Installing Gutter Miters

Locate the Miters for the appropriate locations. Secure the Miter to the roof edge using the #10-13x1" S.S. Panhead Woodscrews (provided) every pre-punched hole or 12" o.c. maximum.

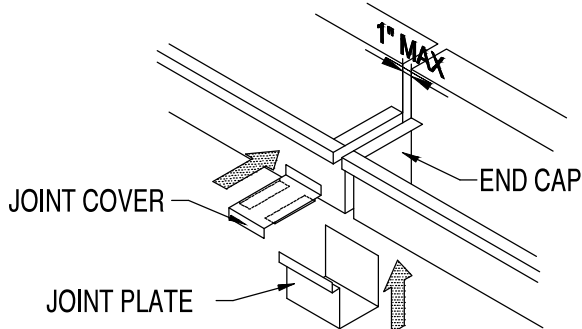

STEP 4 : Installing Expansion Joints (If Required)

Install expansion joint in location as specified on roof plans. An expansion joint will consist of two (2) pre-fabricated End Caps, one (1) Joint Plate, and one Joint Cover. Gap the End Caps at 1" maximum. Slide the Joint Plate onto the Gutter, then secure with Pop Rivets to one of the gutter ends. Place the Joint Cover over the End Cap lips and secure with Pop Rivets to only one of the gutter ends.

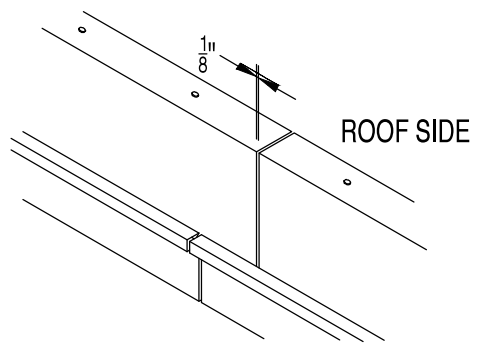

STEP 5 : Installing Gutter HD Straight Lengths

Begin from the End Caps/Miters working inward to the center. Allow $\frac{1}{8}$ " gap between Gutter sections for thermal expansion. Secure gutter to roof with #10-13x1" S.S. Panhead Woodscrews (Provided) at 12" on center in each pre-punched hole.

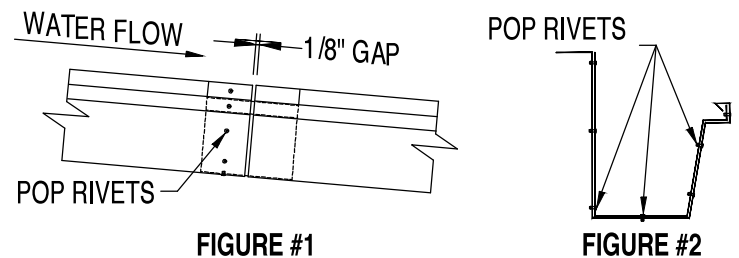

FIGURE #1

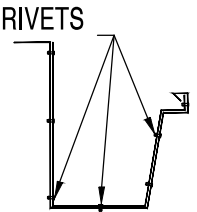
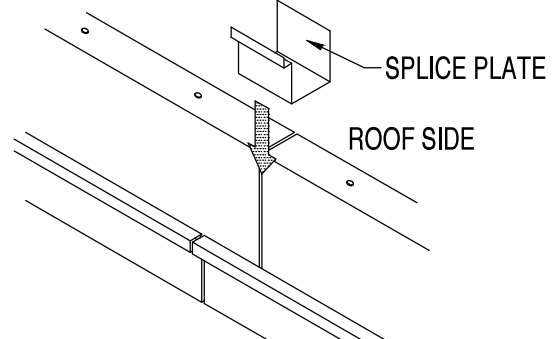
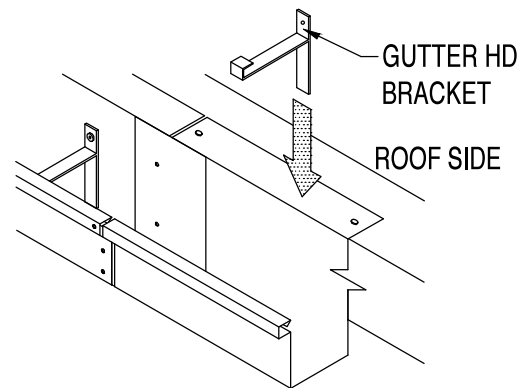

FIGURE #2



STEP 6 : Installing Gutter HD Joint Splices

Locate the joint splice and apply a continuous bead of urethane Tube Sealant to both sides of the joint inside the gutter. Slide the Splice Plate down into the gutter and secure with Pop Rivets on the up slope side of the splice as shown in Figure #1 and #2.



STEP 7 : Installing Gutter HD Brackets

Hook the top part of the Gutter HD Bracket into the face lip of the gutter. Rotate the bracket down into the gutter and secure the bracket through the gutter, into the treated wood nailer, with one (1) #9-13x1 1/2" S.S. Woodscrew. Install brackets at 24" on center maximum. Install roof membrane into Gutter per roof manufacturer's instructions.